

## VANE PUMPS type \*\*V

- Fixed displacement vane pumps
- Integral hydraulic balancing for high pressure operating
- Clockwise rotation (counter clockwise on request)
- Very low noise level
- Suitable for hydraulic oils according to ISO 6743/4
- Recommended oil viscosity from 20cSt to 80cSt (max permissible viscosity at the start up to 800cSt) according to class ISO 3448
- Temperature range from  $-20^{\circ}\text{C}$  to  $+70^{\circ}\text{C}$
- Easy maintenance: pumping cartridge can be replaced in a few minutes
- Recommended fluid contamination level: 18/16/14 according to ISO 4406/99

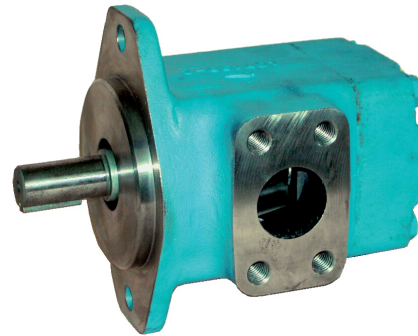

PERFORMANCE DATA					
ORDERING CODE	DISPLACEMENT [cm <sup>3</sup> /rev]	P <sub>MAX</sub> [bar]	ABSORPTION at P <sub>MAX</sub> and 1500rpm [kW]	N <sub>MAX</sub> [rpm]	MASS [kg]
20V 8 A1A 22R	27	175	13	1800	12,0
20V 11 A1A 22R	36		17		14,8
25V 14 A1A 22R	45		21		
25V 17 A1A 22R	55		26		
25V 21 A1A 22R	67		32		

TYPICAL SECTION	
	1 Body
	2 Rotor with vanes
	3 Balanced plates
	4 Shaft

**OVERALL DIMENSIONS**

**20V**

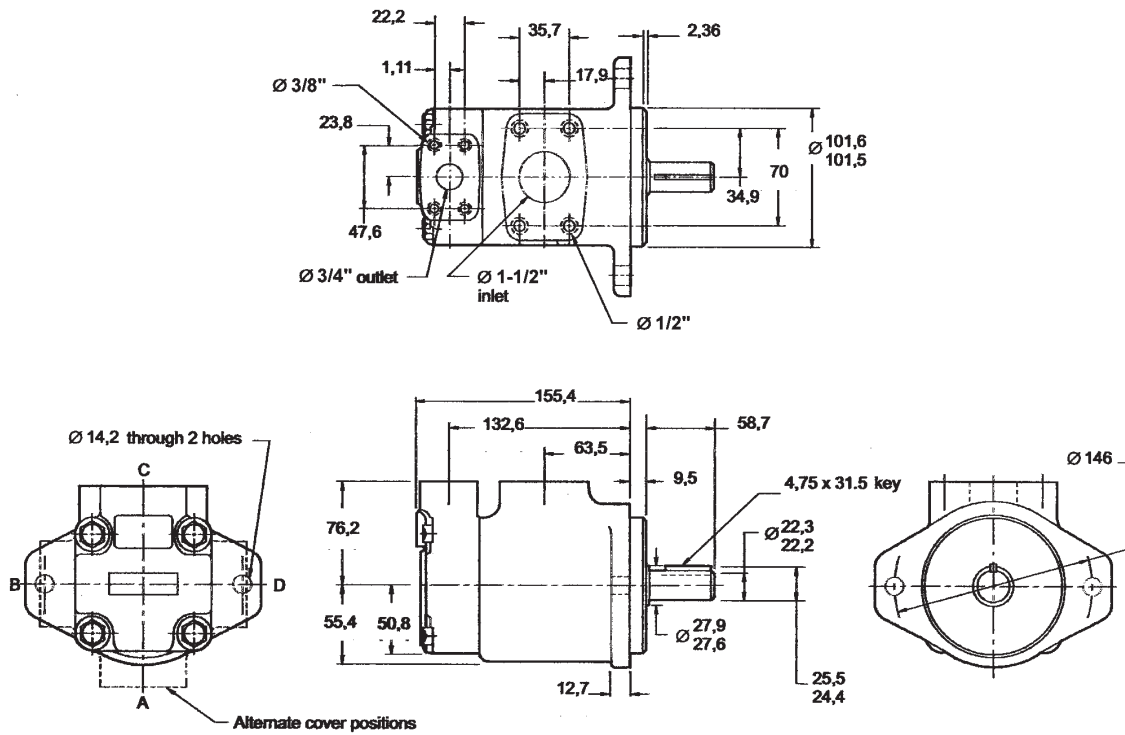

**25V**

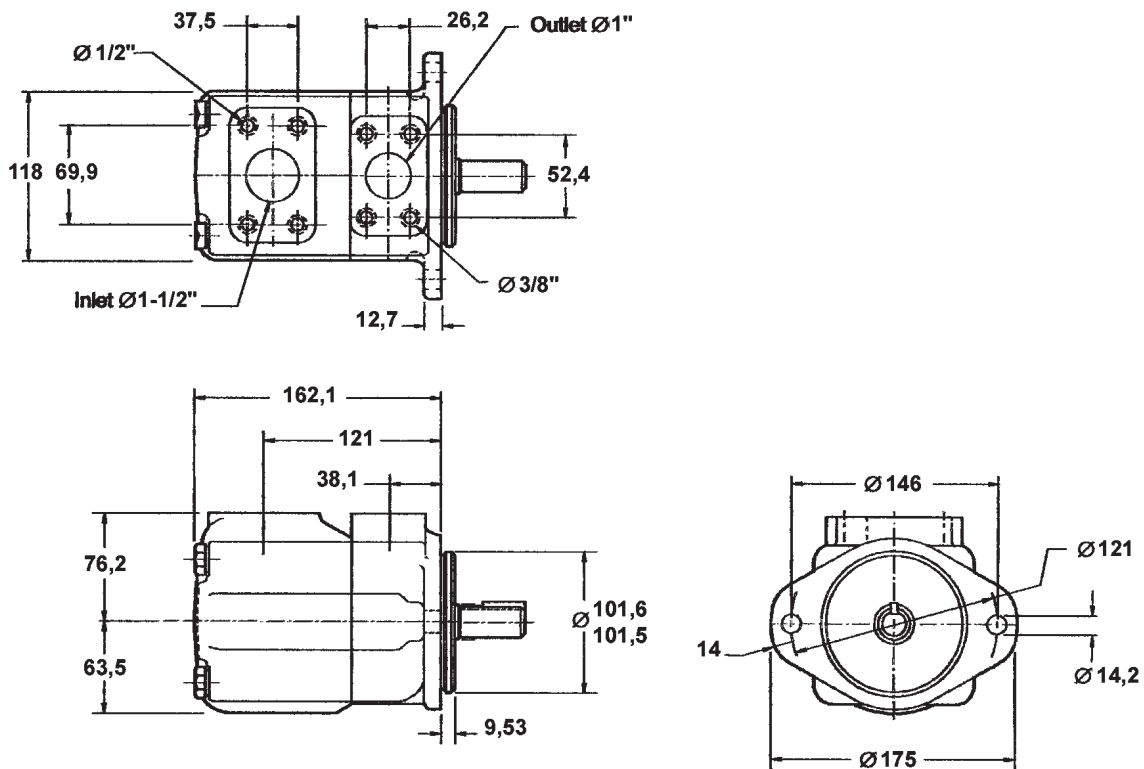

Subject to technical and dimensional changes without notice